

**PLAN**

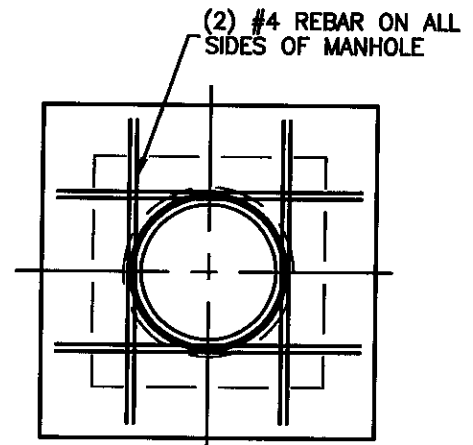

MAIN TOP SLAB REINFORCING NOT SHOWN, TO BE INSTALLED PER WALL REQUIREMENT.

**TOP SLAB REINFORCING PLAN**

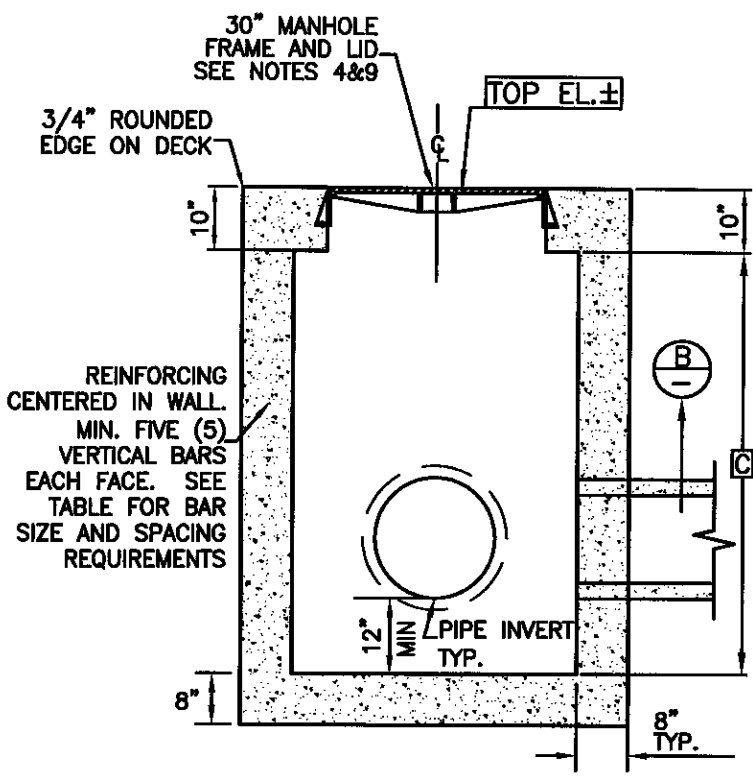

**DETAIL A**

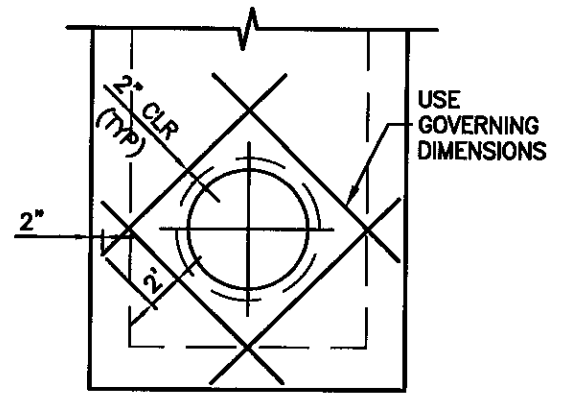

NOTE: MAIN WALL REINFORCING NOT SHOWN

**SECTION B**

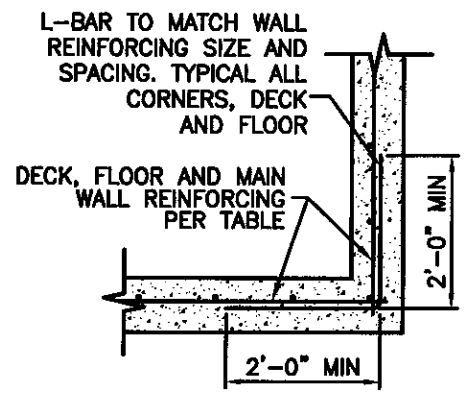

**DETAIL 1**

LAST UPDATED: 03/06/06

**ROOSEVELT WATER CONSERVATION DISTRICT**

**MANHOLE: FOUR SIDED**

MINIMUM REQUIREMENTS		
WALL DIMENSION		REINFORCING STEEL
PIPE DIAMETER	A, B	
36" OR LESS	48"	#4 @ 12" E.W. IF C ≤ 8' OR
42"	56"	
48"	68"	
54" OR 60"	80"	#5 @ 12" E.W. IF C > 8'
66" OR 72"	92"	
78" OR 84"	104"	

### NOTES

1. STRUCTURAL CONCRETE SHALL BE 3000 PSI @ 28 DAYS.
2. REINFORCING STEEL SHALL COMPLY WITH MAG SPEC 727.
3. SEE PLAN AND PROFILE DRAWING FOR CORRECT ORIENTATION OF MANHOLE.
4. USE 30" MANHOLE FRAME AND LID PER DEETER 1296B BOLTED AND GASKETED OR APPROVED EQUAL. LID SHALL HAVE RAISED LETTERING 2" IN HEIGHT STATING "RWCD IRRIGATION". FOR PRESSURE MANHOLES, SEE NOTE 9.
5. EXACT ELEVATION OF ROADWAY SURFACE OR SIDEWALK TO BE SET BY LICENSEE'S ENGINEER.
6. FIELD CUT REBAR AT MANHOLE.
7. CONCRETE SHALL BE PLACED WITH NO COLD JOINTS. ALL CONCRETE SHALL BE VIBRATED DURING PLACEMENT.
8. DIMENSIONS A AND B SHALL NOT EXCEED 104" AND DIMENSION C SHALL NOT EXCEED 180"
9. FOR PRESSURE MANHOLES, MAXIMUM HEAD SHALL NOT EXCEED 30" ABOVE RIM ELEVATION. COVER SHALL HAVE 2" LETTERING "RWCD IRR PMH".
10. A SURVEY HUB SHALL BE SET AT ALL MANHOLES PRIOR TO RWCD INSPECTION.
11. MANHOLE BACKFILL SPECIFICATIONS SHALL BE PER ADJACENT TRENCH BACKFILL SPECIFICATIONS EXCEPT TO PROVIDE JETTED AB OR 1/2 SACK SLURRY UP TO THE SPRINGLINE OF PIPE OR AS DIRECTED BY RWCD INSPECTOR.
12. FOR TEMPORARY GRADING PROVIDE 4:1 SLOPES FROM RIM ELEVATION TO EXISTING GRADE BEGINNING 2' FROM THE OUTSIDE EDGE OF THE MANHOLE IN ALL DIRECTIONS.

### DESIGN CRITERIA

HS20 HIGHWAY LOADING, 32 KIPS ON REAR AXLE (16 KIPS/WHEEL),  
WHEEL SPACING 6', 30% IMPACT ONE WHEEL CENTERED ON MANHOLE, OTHER WHEEL  
ADJACENT TO MANHOLE.

LAST UPDATED: 03/29/07

Roosevelt Water Conservation District

MANHOLE: FOUR SIDED